

RUZGAR TURBİNİ GENEL GÖRÜNÜMLERİ
(1/125)

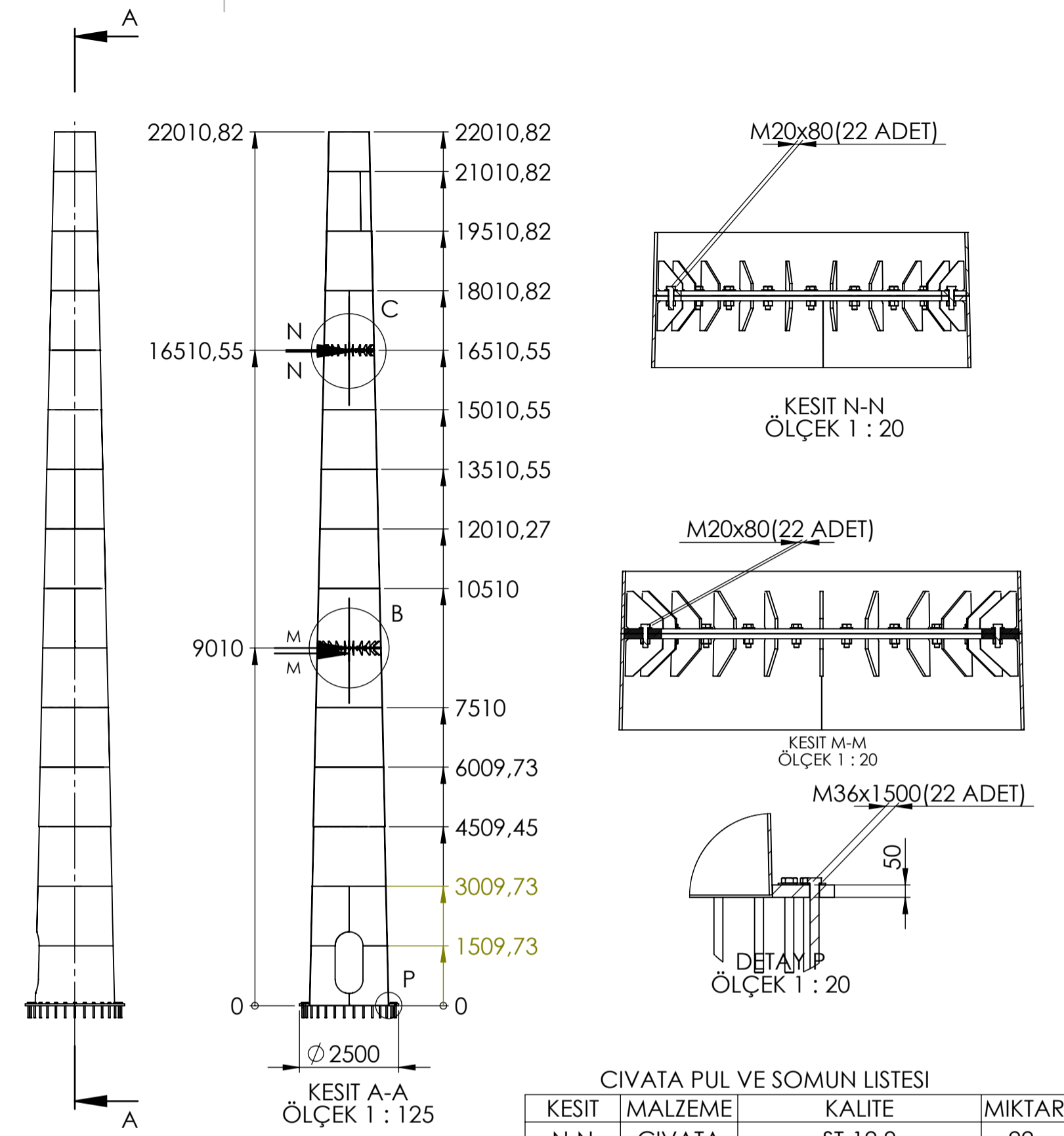

CIVATA PUL VE SOMUN LİSTESİ

KESİT	MALZEME	KALİTE	MIKTAR
N-N	CIVATA	ST-12.9	22
N-N	SOMUN	ST-10	22
N-N	PUL	ST-300 HV	22
M-M	CIVATA	ST-12.9	22
M-M	SOMUN	ST-10	22
M-M	PUL	ST-300 HV	22
DETAY P	CIVATA	ST-42 (ÖZEL YAPIM)	30
DETAY P	SOMUN	ST-10	30
DETAY P	PUL	ST-42	30

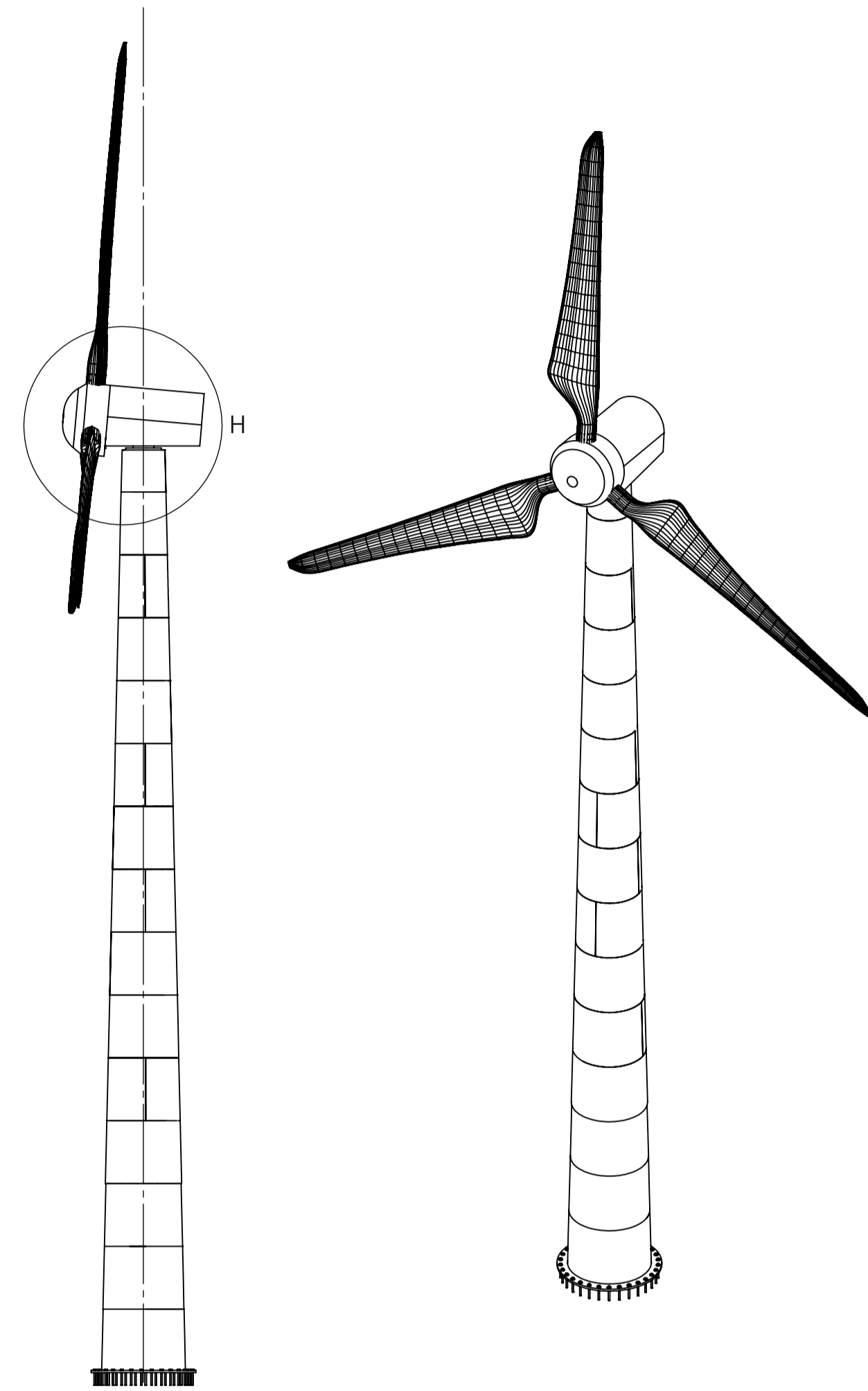
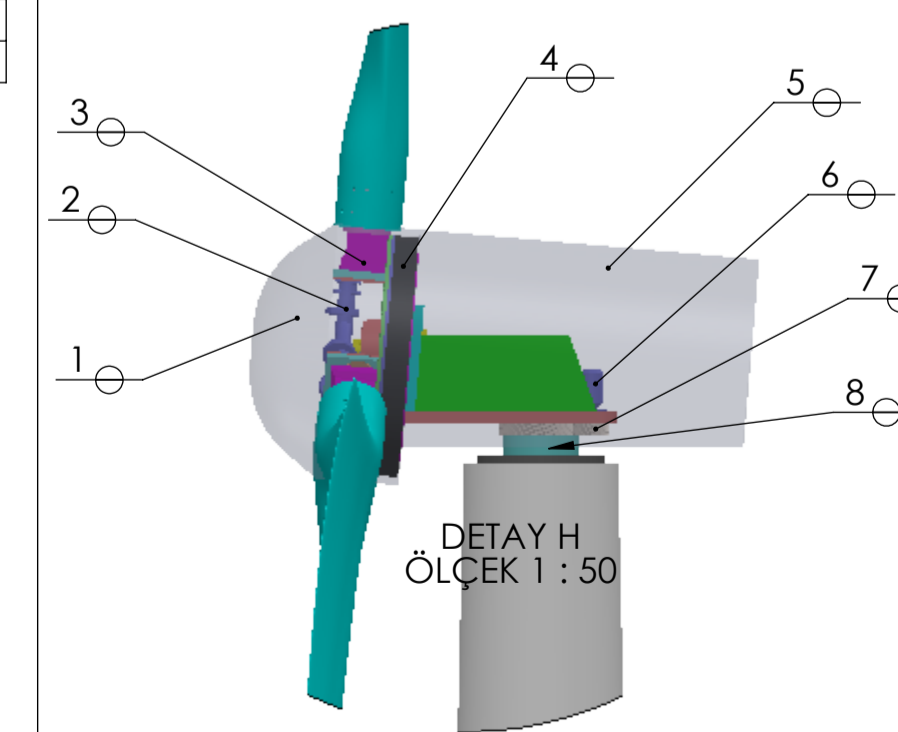
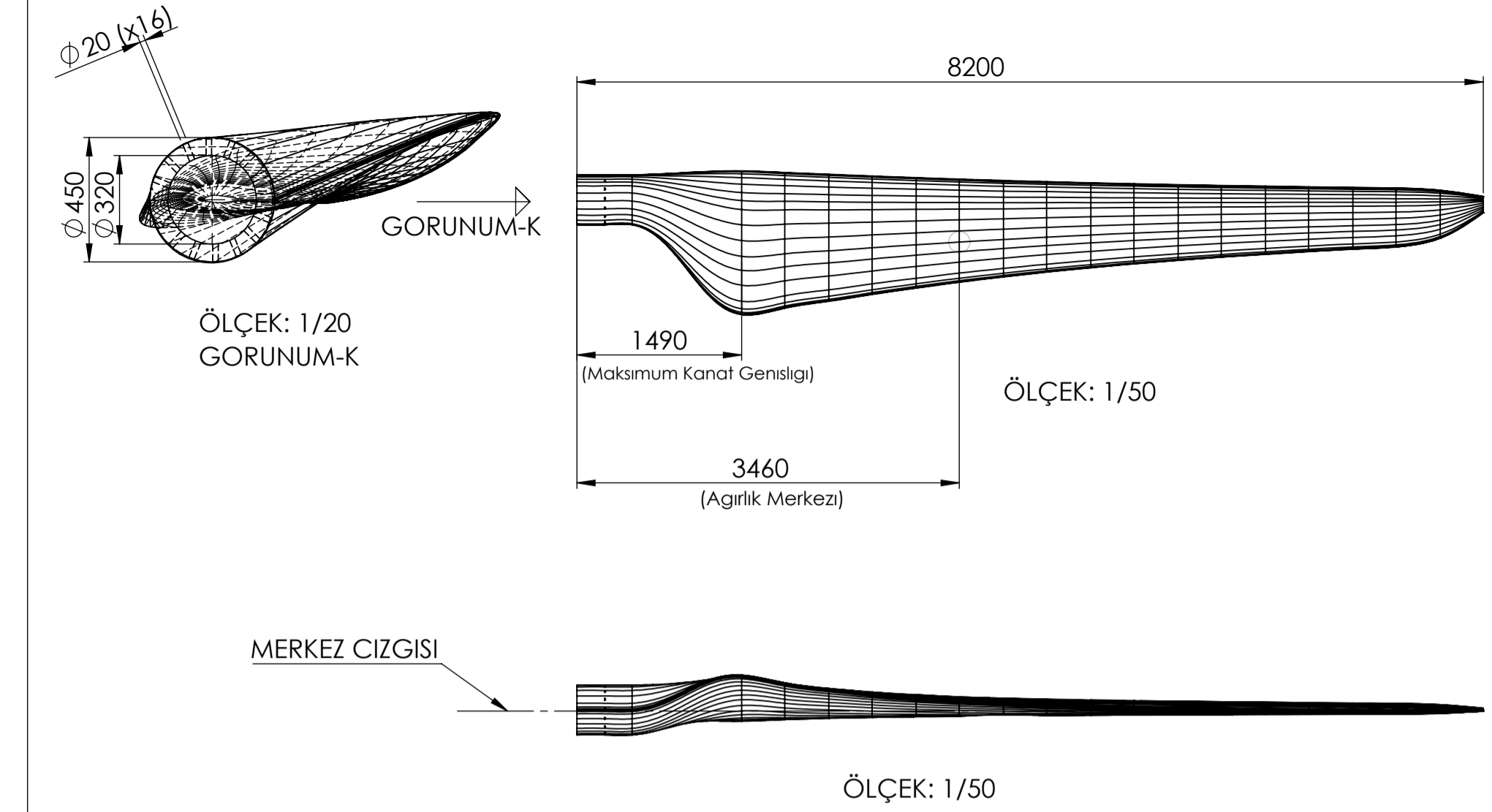
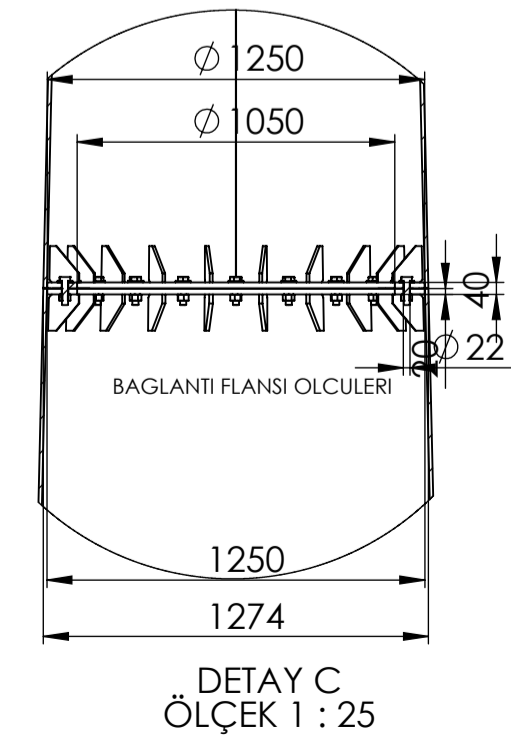
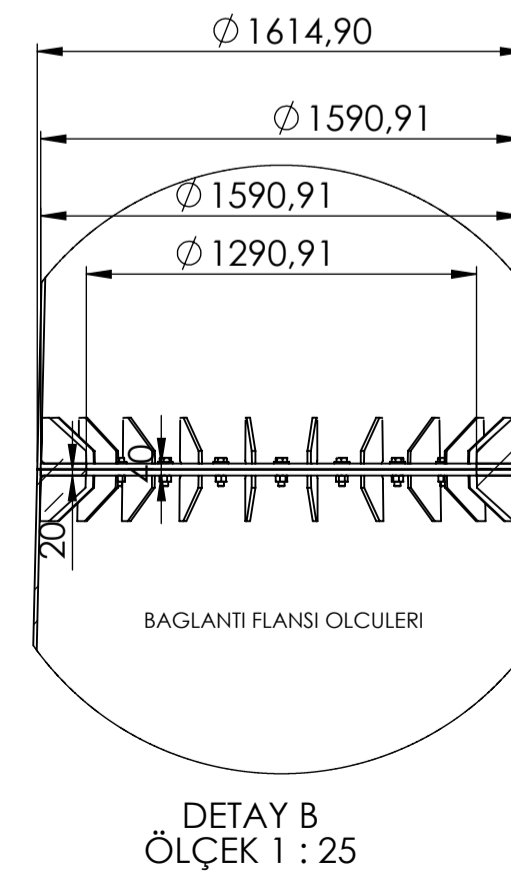

- 1) Burun Hub
- 2) Pitch Kontrol Motoru (Servo)
- 3) Pitch Kontrol Reduktörü
- 4) Alternator
- 5) Rotor Hub
- 6) Yaw Mekanizması Frenli Motorları (2 adet)
- 7) Yaw Mekanizması Dişli Sistemi
- 8) Yaw Mekanizması Rulman Yataklaması